

OneStart/EDEN

A Description of IU's Transaction Processing/Recordkeeping Environment

Rosemary Pleva Flynn
Electronic Records Project Archivist
Indiana University Archives



Indiana University
Electronic Records Project
SAA 2001



Introduction – Portals in Higher Education

*“A campus portal may be defined as **a single integrated point for useful and comprehensive access to information, people, and processes**. While portals have a rapidly evolving set of features and characteristics, they can be described as both **personalized and customized user interfaces providing users with access to both internal and external information**. Portals can be used for a variety of activities which generally fit into three main categories – **gateways to information, points of access for constituent groups, and community/learning hubs**.”*

*David L. Eisler, “A Portal’s Progress”
Syllabus Magazine, September 2000*



Indiana University
Electronic Records Project
SAA 2001



Introduction – Portals and Recordkeeping

How can archivists and records managers, leverage portals in our efforts to capture, maintain, and preserve electronic records?

At Indiana University . . .

OneStart

Campus portal

EDEN

(Enterprise Development ENvironment)

Shared infrastructure



Indiana University
Electronic Records Project
SAA 2001

INDIANA UNIVERSITY
OxeStart

Background – IU's IT Strategic Plan

- Five-year Information Technology (IT) Strategic Plan released 1998
- Replacement or re-engineering of several enterprise wide applications
 - PeopleSoft's HRMS and SIS
- Excellent opportunity to integrate all of the enterprise applications at IU through a transaction-processing environment
 - Would provide access to these applications through a coordinated, unified front end and an infrastructure made up of components that would be shared among applications



Indiana University
Electronic Records Project
SAA 2001

INDIANA UNIVERSITY
OxeStart

Background – Requirements Gathering

- JAD Session, March 2000
- Meeting participants
 - IT developers and managers
 - Functional areas (HR, Timekeeping, Student Information, Financial Management, Accounts Payable, Purchasing, Electronic Research Administration, Indiana University Information Environment)
- Additional meetings held during the summer



Indiana University
Electronic Records Project
SAA 2001

INDIANA UNIVERSITY
eStart

Background – Portal Vision

- Unified front end to IU services
- Single sign-on and authentication
- 24x7 availability
- Role-based customization
- Usability-tested personalization features
- Application integration
- Adaptive user interface
- Completely user-centered environment.
- Component-based design (CBD)/Web services methodology and standards approach allowing for the development of the shared infrastructure.



Indiana University
Electronic Records Project
SAA 2001

INDIANA UNIVERSITY
eStart

University Archives Involvement

- Not working directly with the PeopleSoft implementation



Indiana University
Electronic Records Project
SAA 2001



University Archives Involvement

- Not working directly with the PeopleSoft implementation
- Active participant on OneStart/EDEN core development team
 - Document creation and workflow requirements gathering



Indiana University
Electronic Records Project
SAA 2001



University Archives Involvement

- Not working directly with the PeopleSoft implementation
- Active participant on OneStart/EDEN core development team
 - Document creation and workflow requirements gathering
 - Development methodology



Indiana University
Electronic Records Project
SAA 2001

INDIANA UNIVERSITY
OxeStart

University Archives Involvement

- Not working directly with the PeopleSoft implementation
- Active participant on OneStart/EDEN core development team
 - Document creation and workflow requirements gathering
 - Development methodology
- Fall 2000 to Spring 2001– portal development



Indiana University
Electronic Records Project
SAA 2001

INDIANA UNIVERSITY
OxeStart

University Archives Involvement

- Not working directly with the PeopleSoft implementation
- Active participant on OneStart/EDEN core development team
 - Document creation and workflow requirements gathering
 - Development methodology
- Fall 2000 to Spring 2001– portal development
- Spring/Summer 2001 – additional workflow requirements gathering



Indiana University
Electronic Records Project
SAA 2001

INDIANA UNIVERSITY
OxeStart

OneStart & EDEN Component-Based Development

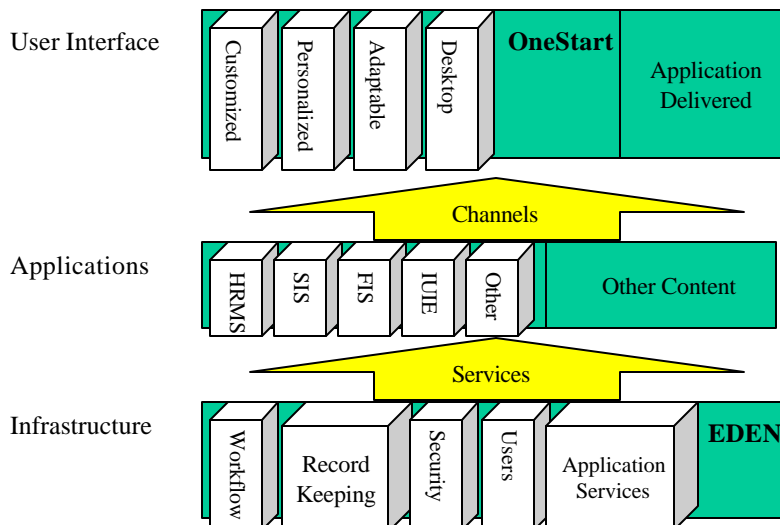

Indiana University
Electronic Records Project
SAA 2001

INDIANA UNIVERSITY
OxeStart

Conceptual Design – Advantages of CBD

- Creates a repository of reusable business functions that also allows for the replacement of specific functions
- Aids rapid application development by assembling existing components and services.
- Can improve the agility, flexibility, and scalability of an application.
- As long as components agree upon the protocol to be used, an application does not have to reach into another application's database for information.



Indiana University
Electronic Records Project
SAA 2001

INDIANA UNIVERSITY
eStart

Conceptual Design – Workflow

Workflow is *"the automation of a business process, in whole or part, during which documents, information or tasks are passed from one participant [human or machine] to another for action, according to a set of procedural rules."*

<http://www.e-workflow.org/>

"Starting from creation and ingestion, we should integrate the workflow process with the preservation process: appraisal, verification, maintenance and, eventually, retirement."

Su-Shing Chen "The Paradox of Digital Preservation"
Computer (IEEE Computer Society), March 2001



Indiana University
Electronic Records Project
SAA 2001

INDIANA UNIVERSITY
eStart

Conceptual Design – EDEN Workflow Engine

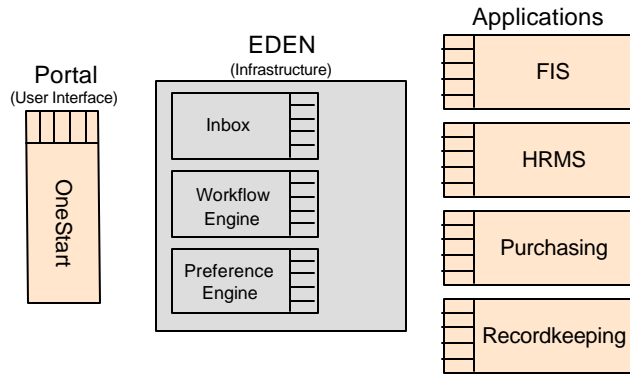

Indiana University
Electronic Records Project
SAA 2001

INDIANA UNIVERSITY
OxStart

Conceptual Design – Routing an E-Doc

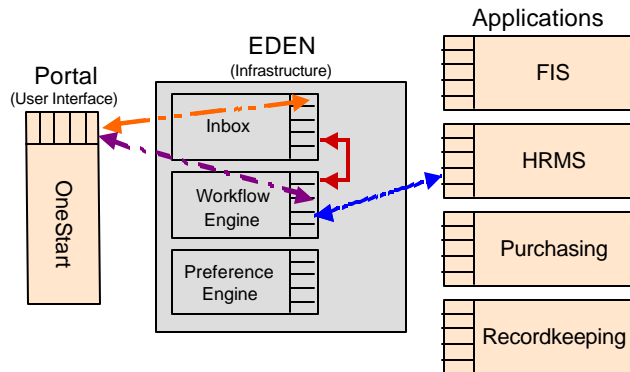

Indiana University
Electronic Records Project
SAA 2001

INDIANA UNIVERSITY
OxStart

Conceptual Design – Workflow and Electronic Recordkeeping

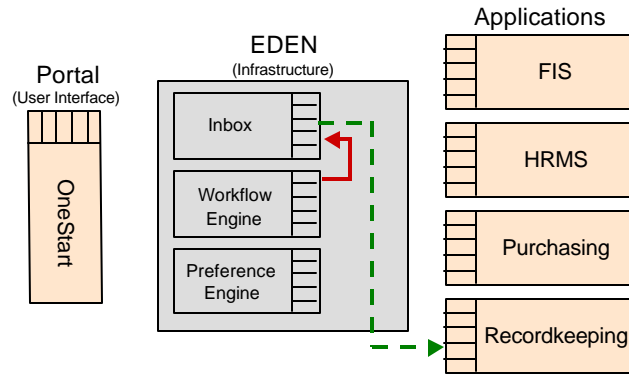

Indiana University
Electronic Records Project
SAA 2001

INDIANA UNIVERSITY
OneStart

IU Electronic Recordkeeping Project

<http://www.indiana.edu/~libarch/ER>

OneStart/EDEN

Portal

<http://onestart.iu.edu>

Project Website

<http://onestart.iu.edu/project>



Indiana University
Electronic Records Project
SAA 2001

INDIANA UNIVERSITY
OneStart